

Block Camera User's Manual

Version 1.1.1

Welcome

Thank you for purchasing our block camera!

This user's manual is designed to be a reference tool for your system.

Please read the following safeguard and warnings carefully before you use this series product!

Please keep this user's manual well for future reference!

Important Safeguards and Warnings

1 . Electrical safety

- All installation and operation here should conform to your local electrical safety codes.
- We assume no liability or responsibility for all the fires or electrical shock caused by improper handling or installation.
- We are not liable for any problems caused by unauthorized modification or attempted repair.

2 . Transportation Security

- No heavy stress, violent vibration or water splash are allowed during transportation, storage and installation.
- Please use the original packing material (or the material of the same quality) when you ship it back to the manufacturer.

3 . Installation

- Do not apply power to the product before completing installation.
- Do not put object on the product.

4 . Environment

- This series product should be installed in a cool, dry place away from direct sunlight, inflammable, explosive substances and etc.
- Please keep it away from the electromagnetic radiation object and environment.
- Please keep the sound ventilation.
- Do not allow the water and other liquid falling into the device.
- Please make sure the CCD (CMOS) component is out of the radiation of the laser beam device. Otherwise it may result in CCD (CMOS) optical component damage.

5. Daily Maintenance

- Current series product has no power button. Please unplug all corresponding power cables before your begin installation or daily maintenance work.
- Please keep the dustproof cap back to protect the CCD or CMOS part if the device does not work for a long time.
- Do not touch CCD (CMOS) component. You can use the blower to clean the dust on the surface of the device. You can use the dry cloth with some alcohol or mild detergent to clear if necessary.
- Do not use the volatility solvent such as the benzene or thinner, or detergent with strong abrasibility. It may result in lens damage or it may adversely affect the device performance.
- If there is too much dust, please use the water to dilute the mild detergent first and then use it to clean the device. Finally use the dry cloth to clean the device

6. About Accessories

Always use all the accessories recommended by manufacturer.

Before installation, please open the package and check that all the components are included in the package:

Contact you local retailer ASAP if something is missing in your package.

Table of Contents

1	General Introduction	1
1.1	Overview	1
1.2	Features	1
2	Framework.....	2
2.1	Rear Panel.....	2
2.2	Side Panel	5
2.3	Front Panel.....	5
3	Installation.....	7
3.1	Pedestal	7
3.2	SD Card	7
3.2.1	General Series	7
3.2.2	Special Series	8
	Important.....	8
	Please note, the following operation is for professional engineer only. We are not liable for any problem resulting from the unauthorized operation.	8
3.3	Bidirectional Talk	10
3.4	I/O Port.....	10
3.5	Lens Protection Film	11
4	Quick Configuration Tool.....	12
4.1	Overview	12
4.2	Operation	12
5	Web Operation.....	15
5.1	Network Connection.....	15
5.2	Login and Logout.....	15

6 FAQ 18

Appendix Toxic or Hazardous Materials or Elements 19

1 General Introduction

1.1 Overview

This series camera integrates the traditional camera and network video technology. It adopts audio/video data collection, transmission, and storage together.

This series network camera uses standard H.264 video compression technology, PCM, G.711a/u audio compression technology and etc. It supports bidirectional talk, digital water mark and etc.

This series network camera is widely used in many environments such as office, bank, road monitor and etc.

1.2 Features

User Management	<ul style="list-style-type: none">● Different user rights for each group, one user belongs to one group.● The user right can not exceed the group right.
Data Transmission	<ul style="list-style-type: none">● Support Ethernet transmission.● Support RS485 control function.● Support BNC analog video transmission.
Storage Function	<ul style="list-style-type: none">● Support local storage and Micro SD card storage.● Support centralized storage.
Alarm Function	<ul style="list-style-type: none">● Support real-time video detect, internal abnormality detect, external alarm.● Alarm can activate snapshot, record, alarm output, email and etc.
Network Management	<ul style="list-style-type: none">● Realize device configuration and management via Ethernet.● Support device management via web.● Support various network protocols.
Peripheral Equipment	<ul style="list-style-type: none">● Support peripheral equipment control via the RS485 port.
Power	<ul style="list-style-type: none">● Support DC 12V/AC 24V /PoE power supply.

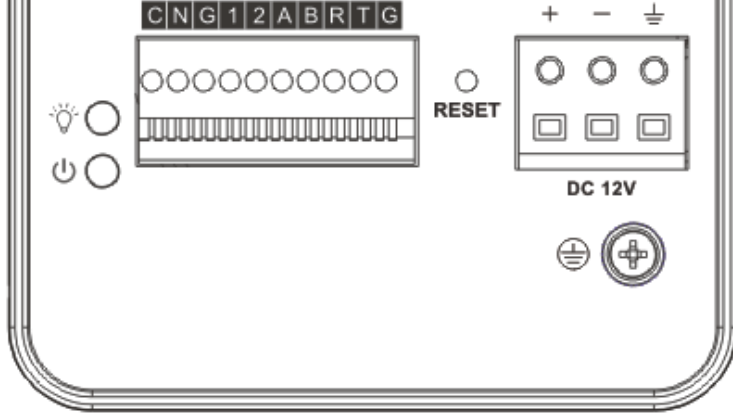

Figure 2-1.

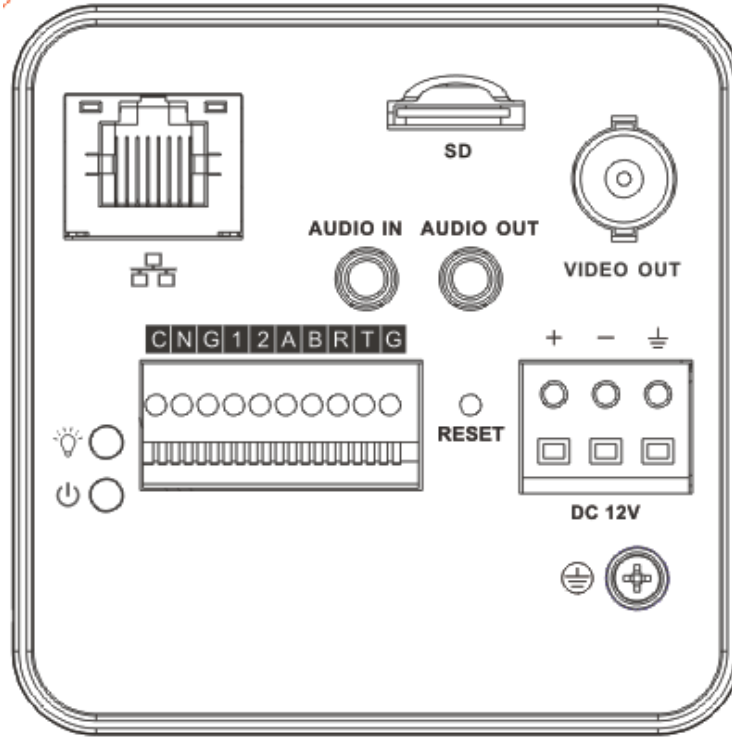



Figure 2-1

Please refer to the following sheet for detail information.

Interface Name		Connector	Function
VIDEO OUT	Video output port	BNC	Output analog video signal. Can connect to TV monitor to view video.
DC 12V	Power port		<ul style="list-style-type: none"> ● Power port. ● Input DC12V

STATUS	Indicator Light		<p>Camera working status indicator light.</p> <ul style="list-style-type: none"> ● System boot up-red light is on ● System upgrades-red light flashes ● System resets-red light flashes. 	
C	1-channel alarm output port		<p>Alarm output port. To output alarm signal to the alarm device.</p> <ul style="list-style-type: none"> ● C: Alarm output public end. ● N: Normal open alarm output end. 	
N				
G	GND			Alarm input ground end.
1	Alarm input port 1			Alarm input port 1. Receive on-off signal from the external alarm source.
2	Alarm input port 2			Alarm input port 2. Receive on-off signal from the external alarm source.
A	RS485 port			RS485_A port, control peripheral device and etc.
B		RS485_B port, control peripheral device and etc.		
R	RS232 port	RS232_RX, RS232 receive end.		
T		RS232_TX, RS232		

			COM send out end.
G	GND		RS232 ground end
RESET	RESET button		<ul style="list-style-type: none"> ● Restore factory default setup. ● When system is running normally (indicator light is green), press the RESET button for at least 5 seconds, system can restore factory default setup.
AUDIO OUT	Audio output port	Audio output 3.5mm JACK port.	Output audio signal to the passive device such as earphone.
AUDIO IN	Audio input port	Audio input 3.5mm JACK port.	Input audio signal from devices such as pick-up.
LAN	Network port	Ethernet port	Connect to standard Ethernet cable.
SD	SD card port		<p>Connect to SD card.</p> <p>Note</p> <ul style="list-style-type: none"> ● When you install the SD card, please make sure current card is not in write mode and then you can install it to the camera. ● When you remove the SD card, please make sure current card is not

			<p>in write mode.</p> <p>Otherwise it may result in data loss or card damage.</p> <ul style="list-style-type: none"> ● Before hot swap, please stop record operation.
	GND		<p>Please make sure the device is securely earthed to prevent the thunderstorm strike.</p>

2.2 Side Panel

Please refer to the following interface for side panel dimension information. The unit is mm. See Figure 2-2.

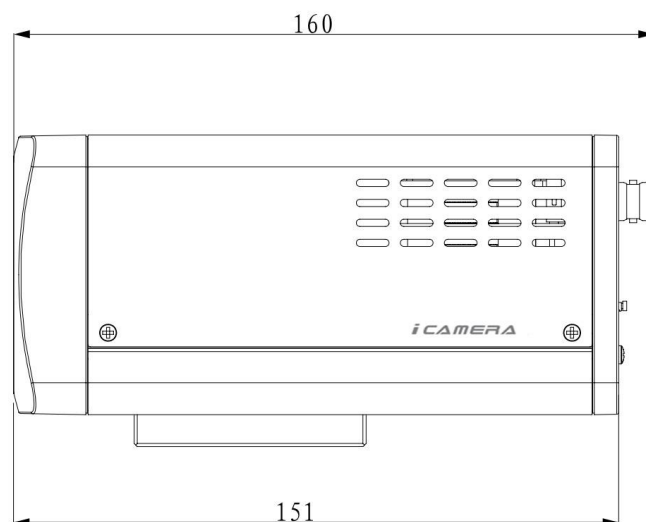

Figure 2-2

2.3 Front Panel

Please refer to the following interface for the front panel information. The unit is mm. See Figure 2-3.

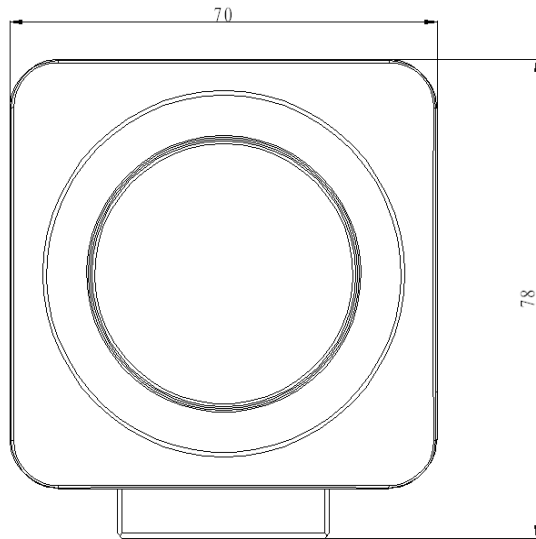

Figure 2-3

3 Installation

3.1 Pedestal

Please refer to the steps listed below to install the pedestal. See Figure 3-1 and Figure 3-2.

- a) Take the connection adapter and four screws from the accessories bag, line up the connection adapter to the four holes at the bottom of the camera and then use the crosshead screwdriver to fix the four screws firmly.
- b) Use M6 screws to secure the camera to the housing or bracket.

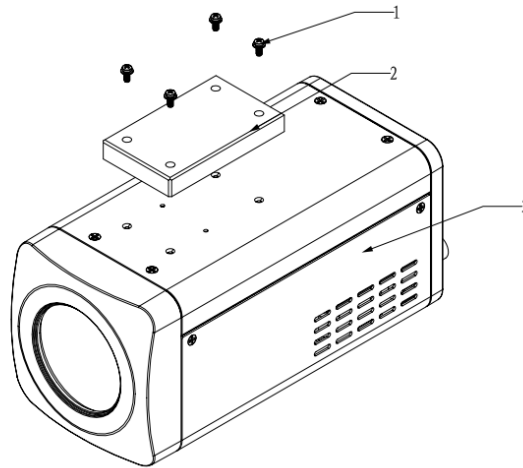

Figure 3-1

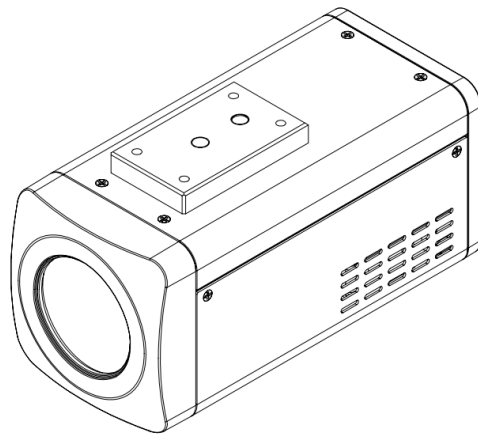

Figure 3-2

3.2 SD Card

3.2.1 General Series

Please refer to the steps listed below to install/remove the SD card.

Installation

Put the SD card to the SD card slot. You can hear a clear sound when the SD is secure firmly. Otherwise, system pops up the card. See Figure 3-3.

Remove

- a) Press the rear end of the SD card, system can pop up the SD card.
- b) Take the SD card out. See and Figure 3-4.

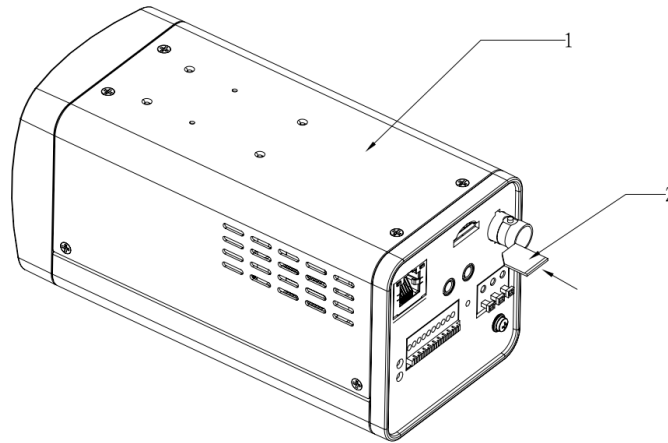

Figure 3-3

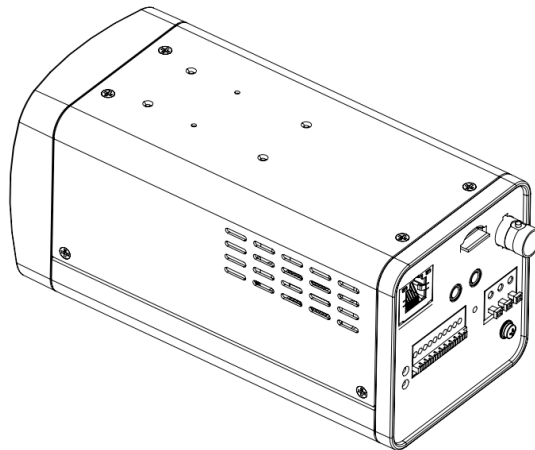

Figure 3-4

3.2.2 Special Series

Important

Please note, the following operation is for professional engineer only. We are not liable for any problem resulting from the unauthorized operation.

- a) Refer to Figure 3-5 to remove the screws.

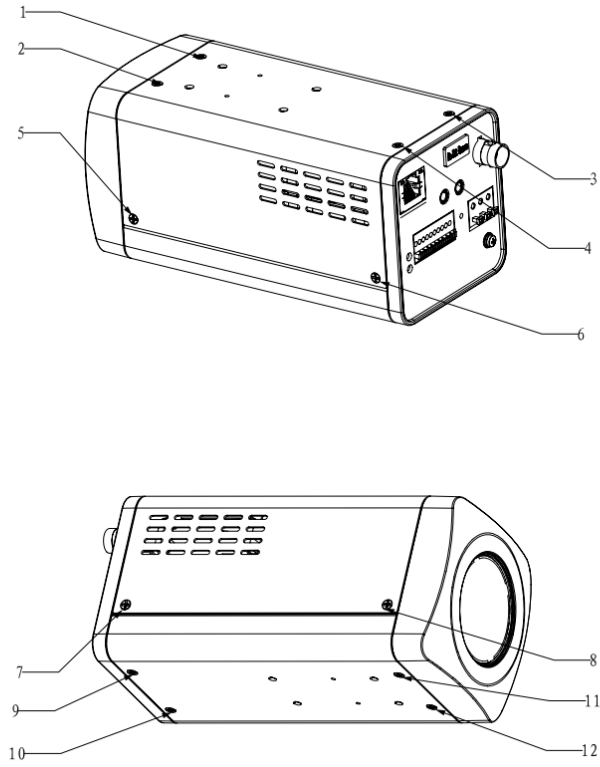

Figure 3-5

b) Refer to Figure 3-6.to open the cover.

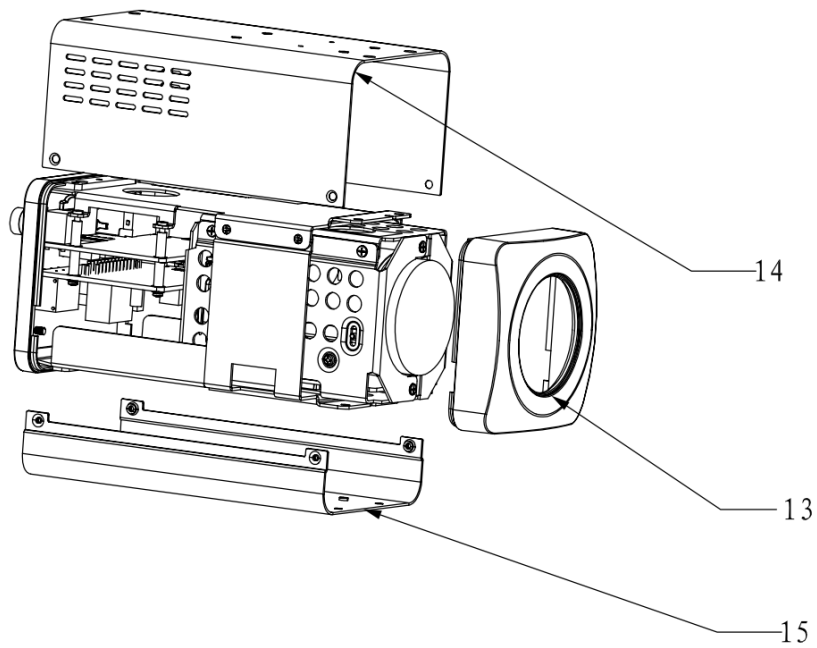

Figure 3-6

c) Take or remove SD card. See Figure 3-7.

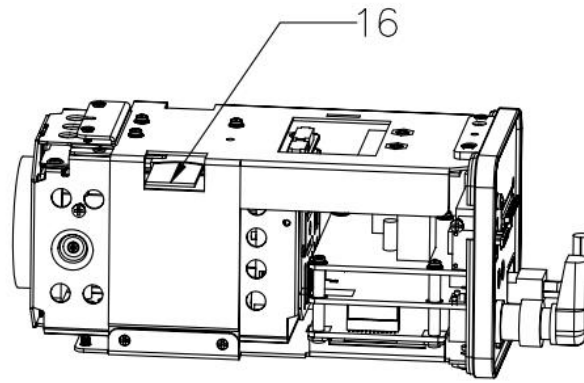

Figure 3-7

- d) Follow the reverse sequence to uninstall/install the screws and covers.

3.3 Bidirectional Talk

Please refer to the steps listed below to connect. See Figure 3-8.

- a) Connect the microphone to the audio input port at the rear panel of the camera.
- b) Connect the earphone to the audio output port at the rear panel of the camera.

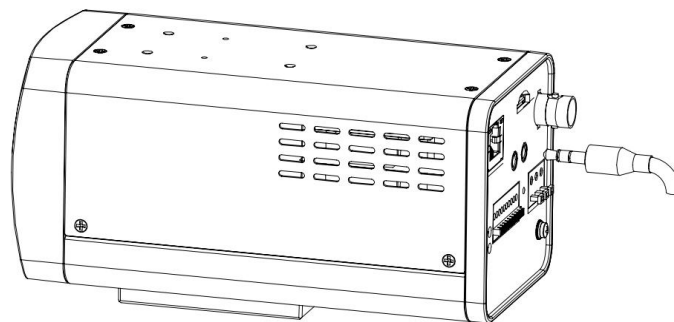

Figure 3-8

3.4 I/O Port

Install Cable

Please follow the steps listed below to install the cable. See Figure 3-9.

Use the small slotted screwdriver to press the corresponding button of cable groove. Insert the cable into the groove and then release the screwdriver.

Remove Cable

Please follow the steps listed below to remove the cable.

Use the small slotted screwdriver to press the corresponding button of cable groove. Remove the cable out of the groove and then release the screwdriver.

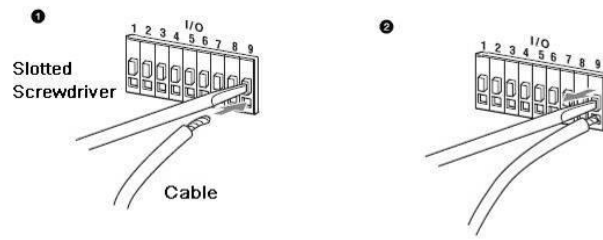

Figure 3-9

3.5 Lens Protection Film

Note

Before you use the camera, please remove the lens protection film to guarantee video quality.

Please refer to Figure 3-10 to remove the lens protection film.

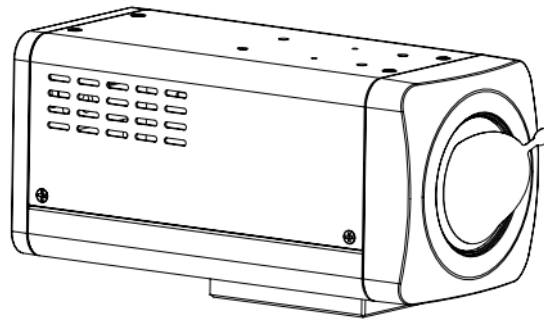

Figure 3-10

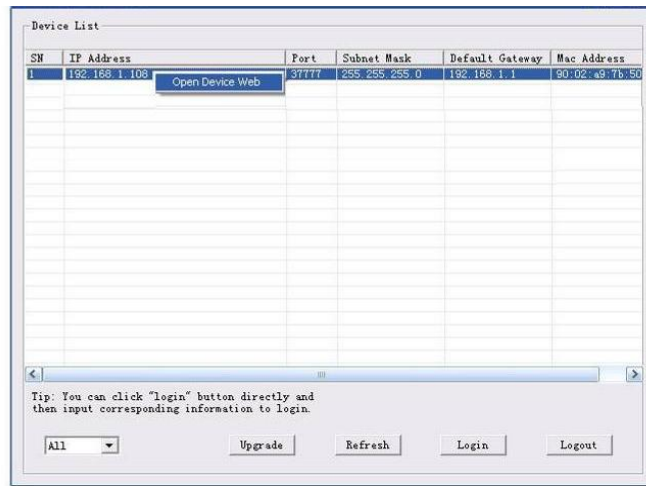

Figure 4-2

Select the “Open Device Web” item; you can go to the corresponding web login interface. See Figure 4-3.

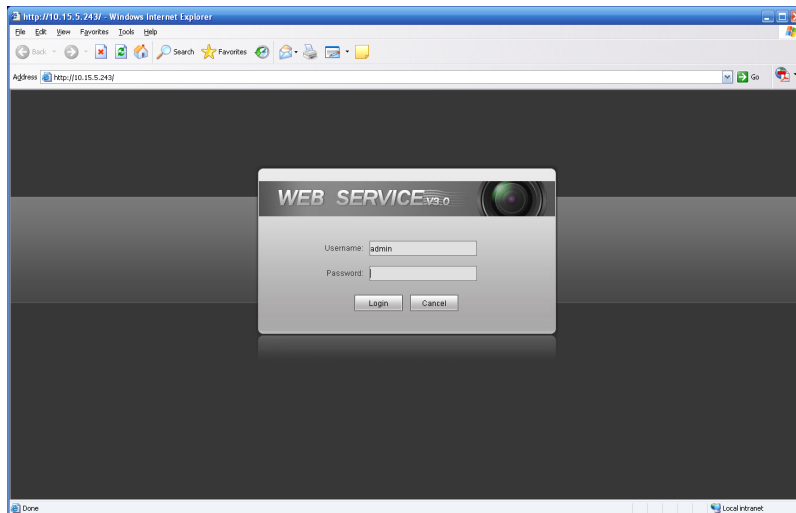

Figure 4-3

If you want to modify the device IP address without logging in the device web interface, you can go to the configuration tool main interface to set.

In the configuration tool search interface (Figure 4-1), please select a device IP address and then double click it to open the login interface. Or you can select an IP address and then click the Login button to go to the login interface. See Figure 4-4.

In Figure 4-4, you can view device IP address, user name, password and port. Please modify the corresponding information to login.

Please note the port information here shall be identical with the port value you set in TCP port in Web Network interface. Otherwise, you can not login the device.

If you are using device background upgrade port 3800 to login, other setups are all invalid.

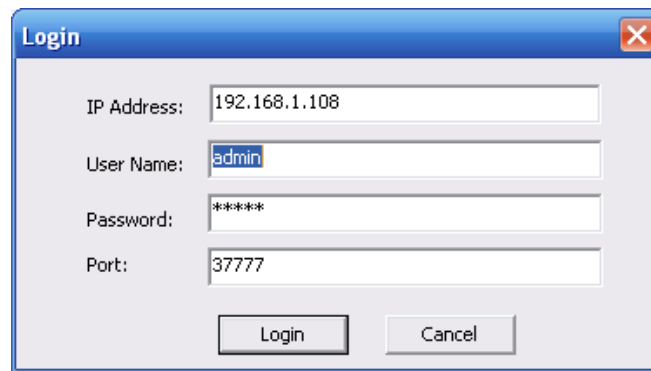

A login dialog box titled "Login" with a close button in the top right corner. It contains four input fields: "IP Address" with the value "192.168.1.108", "User Name" with the value "admin", "Password" with the value "*****", and "Port" with the value "37777". At the bottom, there are two buttons: "Login" and "Cancel".

Figure 4-4

After you logged in, the configuration tool main interface is shown as below. See Figure 4-5.

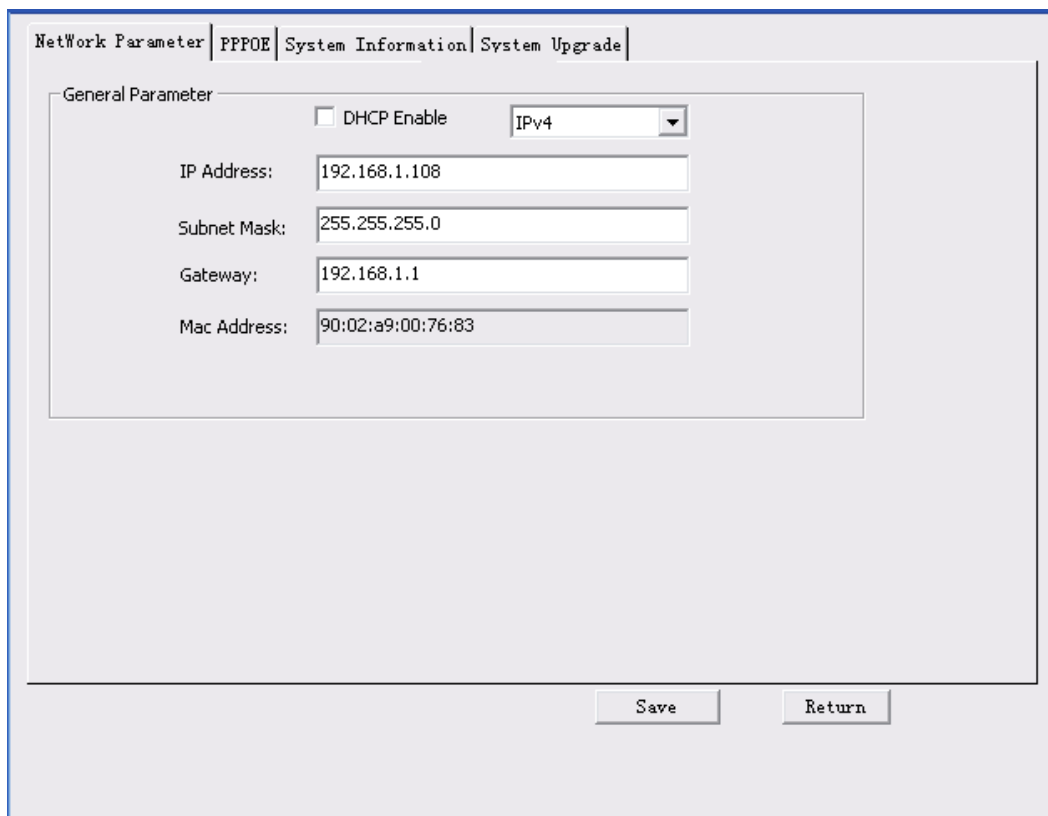

The main interface of the configuration tool, titled "Network Parameter". It has four tabs: "Network Parameter", "PPPOE", "System Information", and "System Upgrade". The "Network Parameter" tab is active. Under the "General Parameter" section, there is a checkbox for "DHCP Enable" which is unchecked, and a dropdown menu set to "IPv4". Below this are four input fields: "IP Address" (192.168.1.108), "Subnet Mask" (255.255.255.0), "Gateway" (192.168.1.1), and "Mac Address" (90:02:a9:00:76:83). At the bottom right, there are two buttons: "Save" and "Return".

Figure 4-5

For detailed information and operation instruction of the quick configuration tool, please refer to the *Quick Configuration Tool User's Manual* included in the resources CD.

5 Web Operation

These series block camera products support the Web access and management via PC. Web includes six modules: encode setup bar, window adjust bar, system menu bar, window function option bar, PTZ control bar, PTZ setup/menu.

5.1 Network Connection

Please follow the steps listed below for network connection.

- Make sure the block camera has connected to the network properly.
- Please set the IP address, subnet mask and gateway of the PC and the block camera respectively. (Please set the same segment for the device and PC if there is no router. Please set gateway and subnet mask if there is a router in the network.).Device default IP address is 192.168.1.108.
- Use order ping `***.***.***.***`(* block camera address) to check connection is OK or not.

5.2 Login and Logout

Open IE and input block camera address in the address bar.

For example, if your camera IP is 192.168.1.108, then please input `http:// 192.168.1.108` in IE address bar. See Figure 5-1.

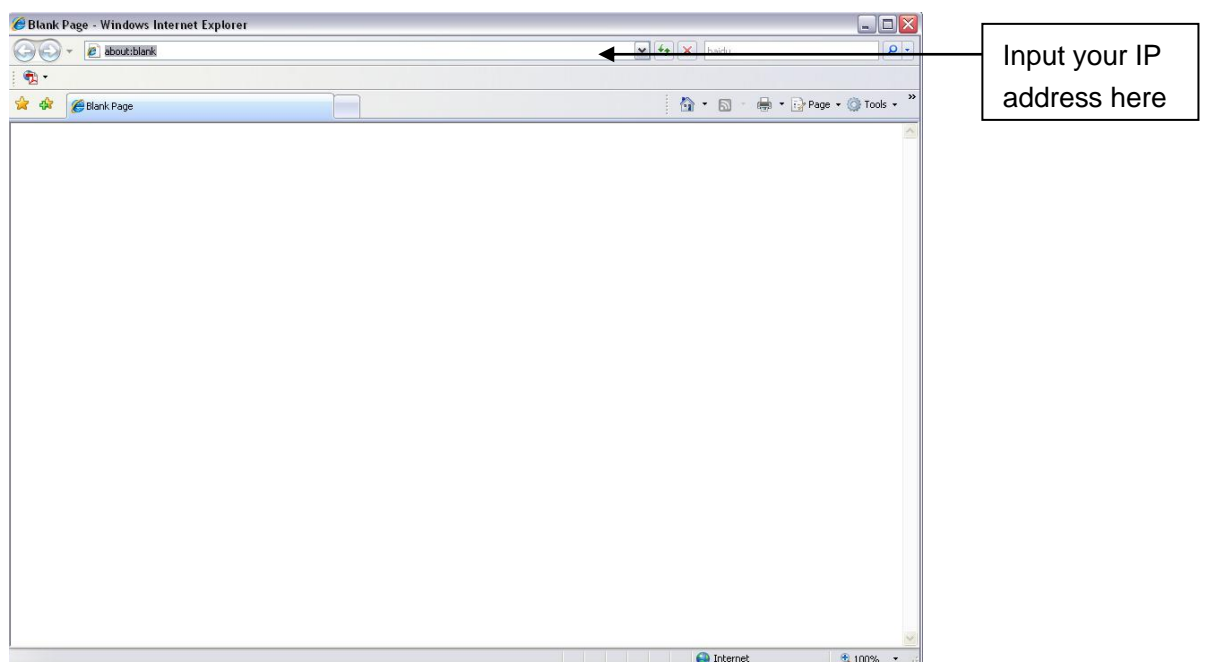

Figure 5-1

The login interface is shown as below. See Figure 5-2.

Please input your user name and password.

Default factory name is admin and password is admin.

Note: For security reasons, please modify your password after you first login.

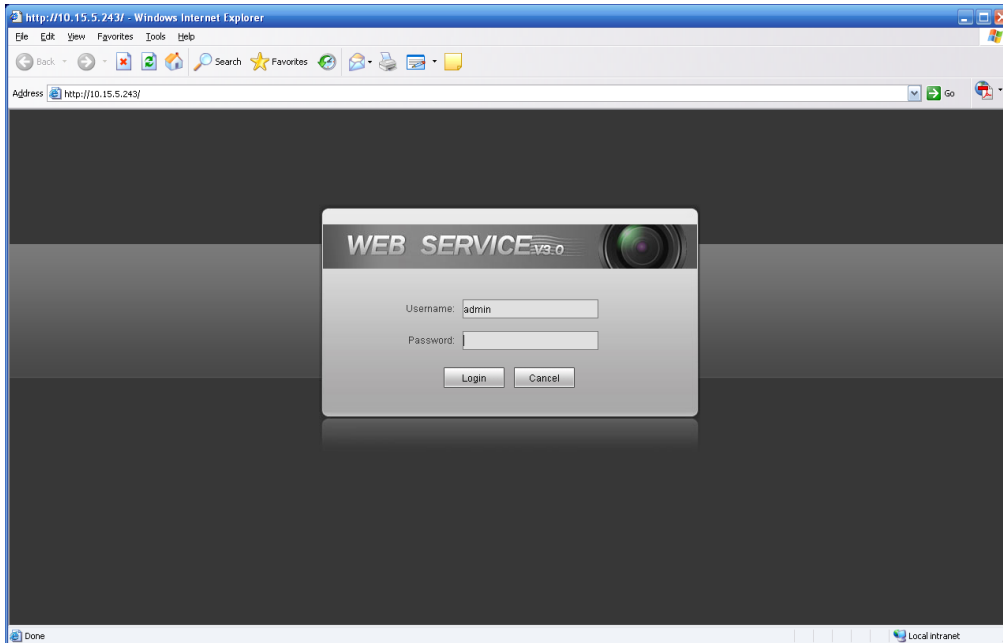

Figure 5-2

If it is your first time to login in, system pops up warning information to ask you whether install control webrec.cab or not after you logged in for one minute. Please click OK button, system can automatically install the control. When system is upgrading, it can overwrite the previous Web too.

If you can't download the ActiveX file, please check whether you have installed the plug-in to disable the control download. Or you can lower the IE security level. See Figure 5-3.

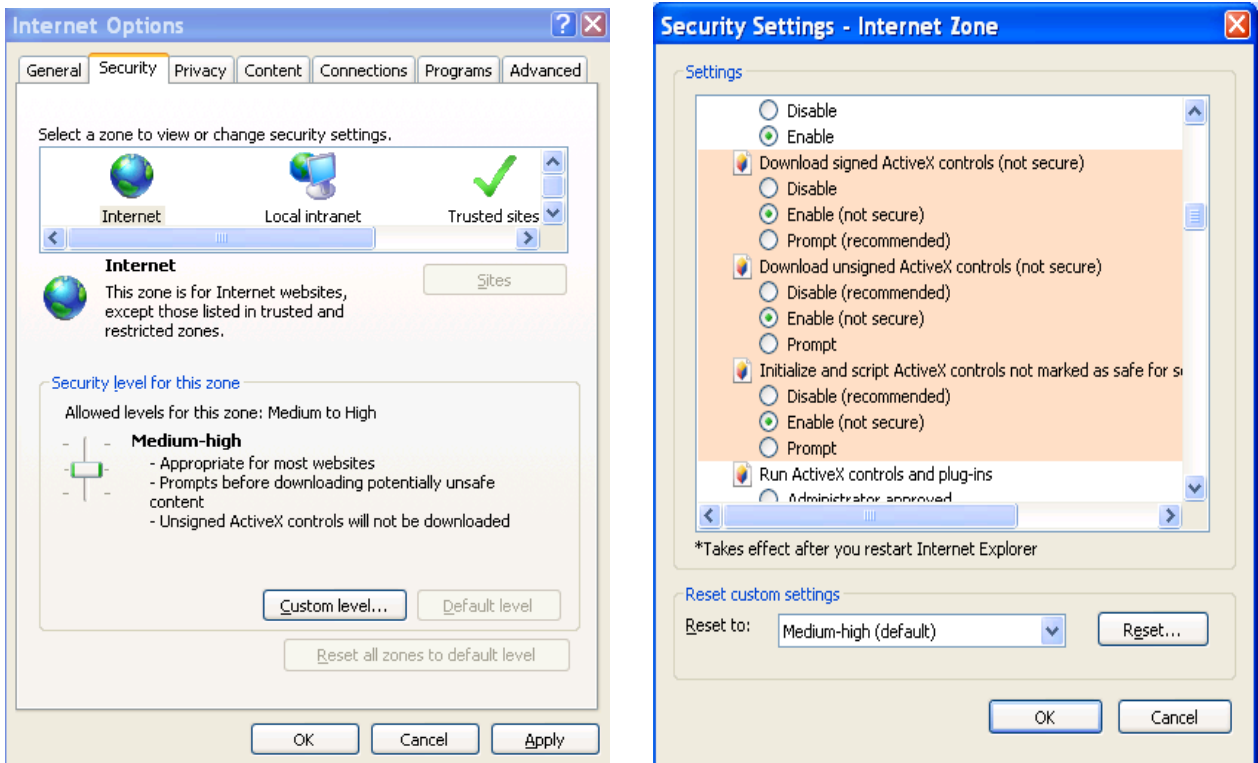

Figure 5-3

After you logged in, you can see the main window. See Figure 5-4.

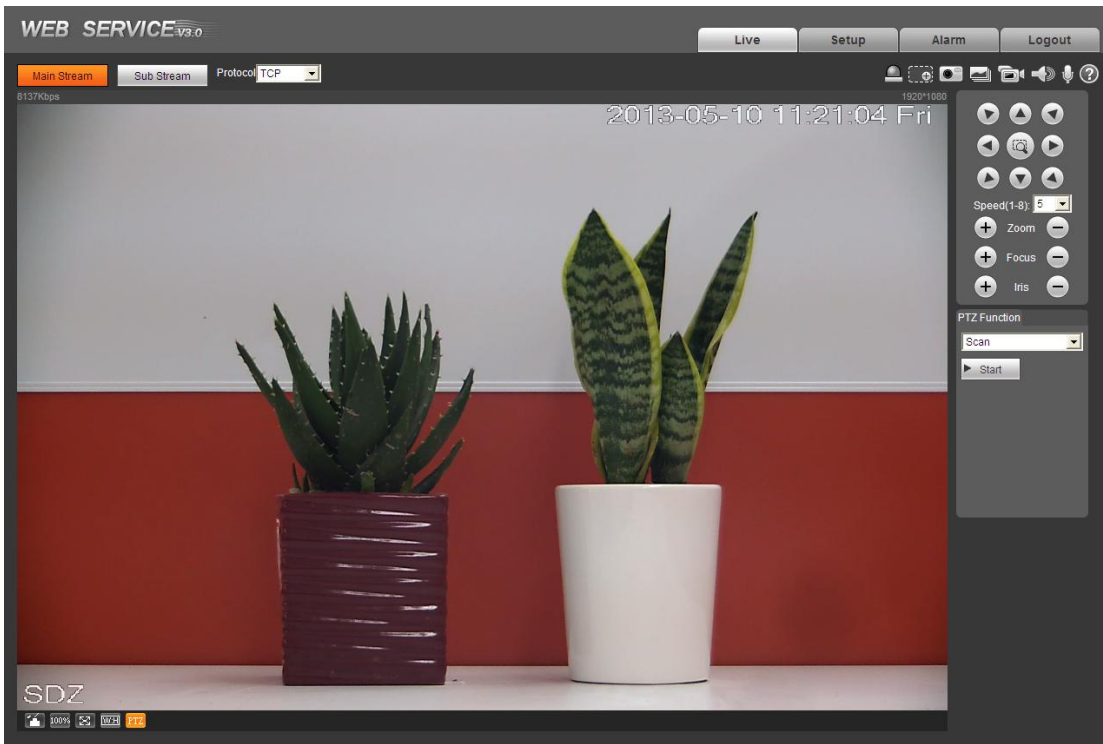

Figure 5-4

Please refer to the Web Operation Manual included in the resource CD for detailed operation instruction.

6 FAQ

Bug	
I can not boot up the device or can not control the device.	Please click RESET button for at least five seconds to restore factory default setup.
Audio function	Please use active device for the audio monitor input, otherwise there is no audio in the client-end.
SD card hot swap	Before draw out SD card, please stop record or snapshot first and then wait for at least 15 seconds to remove the SD card. All the operations before is to maintain data integrity. Otherwise you can lose all the data in the SD card!
SD card write times	Do not set the SD card as the storage media to storage the schedule record file. It may damage the SD card duration.
I can not use the disk as the storage media.	When disk information is shown as hibernation or capacity is 0, please format it first (Via Web).

Appendix Toxic or Hazardous Materials or Elements

Component Name	Toxic or Hazardous Materials or Elements					
	Pb	Hg	Cd	Cr VI	PBB	PBDE
Sheet Metal	○	○	○	○	○	○
Casting fitting	○	○	○	○	○	○
PCB	○	○	○	○	○	○
Camera Driver	○	○	○	○	○	○
Connection Cable	○	○	○	○	○	○
Power (If possible)	○	○	○	○	○	○
Bracket (If possible)	○	○	○	○	○	○
Accessories	○	○	○	○	○	○

O: Indicates that the concentration of the hazardous substance in all homogeneous materials in the parts is below the relevant threshold of the SJ/T11363-2006 standard.

X: Indicates that the concentration of the hazardous substance of at least one of all homogeneous materials in the parts is above the relevant threshold of the SJ/T11363-2006 standard. During the environmental-friendly use period (EFUP) period, the toxic or hazardous substance or elements contained in products will not leak or mutate so that the use of these (substances or elements) will not result in any severe environmental pollution, any bodily injury or damage to any assets. The consumer is not authorized to process such kind of substances or elements, please return to the corresponding local authorities to process according to your local government statutes.

Note

- **This user's manual is for reference only. Slight difference may be found in user interface.**
- **All the designs and software here are subject to change without prior written notice.**
- **All trademarks and registered trademarks mentioned are the properties of their respective owners.**
- **If there is any uncertainty or controversy, please refer to the final explanation of us.**
- **Please visit our website for more information.**